



Concealed Mixing Faucets

B-0512

TAG:

Concealed Mixing Faucet

Architect/Engineering Specifications:

3" concealed mixing faucet with compression cartridges with spring checks, 4-arm handles, 3/8" NPT female inlets and outlet, chrome plated escutcheon. Certified to ASME A112.18.1/CSA B125.1, NSF 61-Section 9 and NSF 372. Meets ADA ANSI/ICC A117.1 requirements.

Job Name _____
 Model Specified _____ Quantity _____
 Variations Specified _____
 Date _____

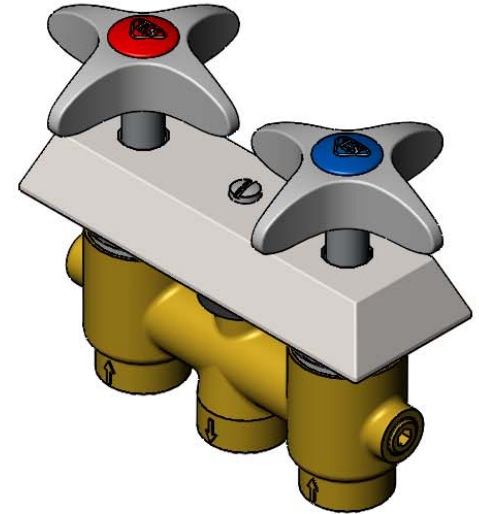
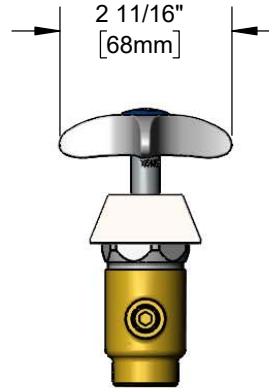
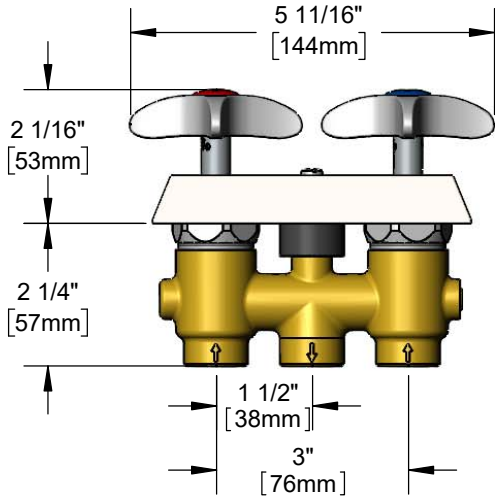

Features & Benefits:

- 3" concealed mixing faucet
- Quarter-turn Eterna compression cartridges w/ spring checks to prevent cross flow of water
- 4-arm handles w/ color coded indexes
- 3/8" NPT female inlets
- 3/8" NPT female outlet
- Chrome plated escutcheon
- Material: Brass body, escutcheon and chrome plated metal handles

Product Compliance:

- ASME A112.18.1 / CSA B125.1
- NSF 61 - Section 9
- NSF 372 (Low Lead Content)
- ANSI A117.1 (ADA)



Warranty: One Year (Limited)

Performance Data:

- Pressure: 20 - 125 psi [1.38 - 8.62 bar]
- Temperature: 40 °F - 140 °F [4.44 °C - 60 °C]
- Flow Rate: 15.40 GPM [58.30 L/min] @ 60 psi [4.14 bar]



ADA Compliant

Optional Handles

- 4" Wrist Action
- Lever
- 4-Arm (Standard)



T&S BRASS AND BRONZE WORKS, INC.



• 2 Saddleback Cove • Travelers Rest, SC 29690
 Ph 800-476-4103 • Fax 864-834-3518
 • Simi Valley, CA • Ph 800-423-0150 • www.tsbrass.com

Date: 09/09/21