



Foot and Knee Pedal Valves

B-0507-509PDL

TAG:

Single Pedal Valve

Architect/Engineering Specifications:

Ledge mounted single knee pedal valve with polished chrome plated solid brass body, aluminum pedal, self-closing valve, 1/2" NPT female inlet and outlet and mounting screws. Certified to ASME A112.18.1/CSA B125.1, NSF 61-Section 9 and NSF 372.

Job Name _____
 Model Specified _____ Quantity _____
 Variations Specified _____
 Date _____

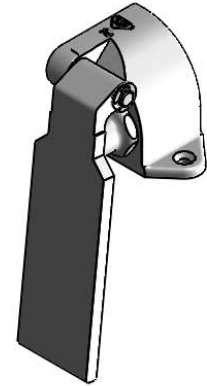
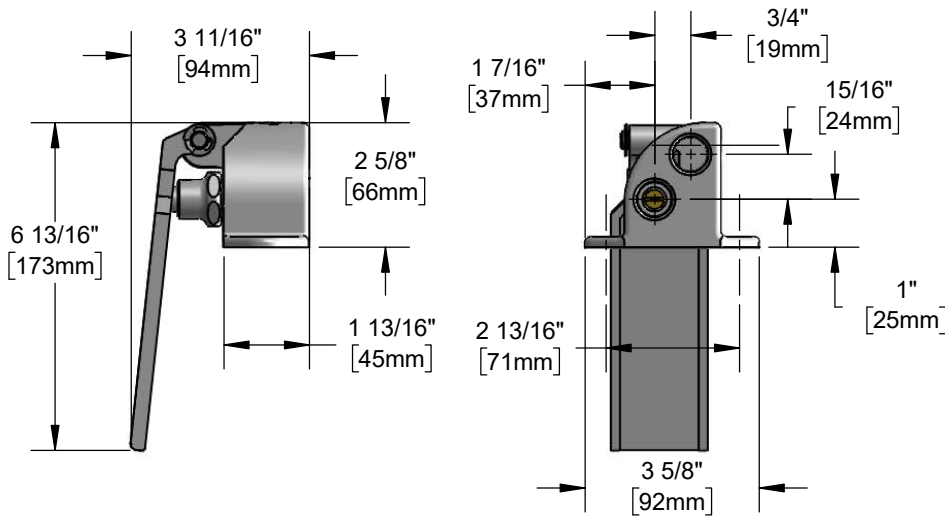

Features & Benefits:

- Ledge mount single pedal valve w/ polished chrome plated brass body
- Aluminum knee pedal
- Self-closing valve
- 1/2" NPT female inlet & outlet
- Mounting screws included
- Material: Polished chrome brass body & aluminum knee pedal

Product Compliance:

- ASME A112.18.1 / CSA B125.1
- NSF 61 - Section 9
- NSF 372 (Low Lead Content)

Warranty: One Year (Limited)

Performance Data:

- Pressure: 20 - 125 psi
- Temperature: 40 °F - 140 °F
- Flow Rate: 10.20 GPM @ 60 psi



Optional Cartridges

- Metering Cartridge



T&S BRASS AND BRONZE WORKS, INC.



• 2 Saddleback Cove • Travelers Rest, SC 29690
 Ph 800-476-4103 • Fax 864-834-3518
 • Simi Valley, CA • Ph 800-423-0150 • www.tsbrass.com

Date: 11/21/19