

#### Architect/Engineering Specifications:

Open epoxy coated steel hose reel with high flow spray valve, 3/8" x 50' hose, ratcheting system, multi-fit bracket, adjustable hose bumper, 3/8" NPT female inlet and 3' connector hose.

Job Name _____
Model Specified _____ Quantity _____
Variations Specified _____
Date _____

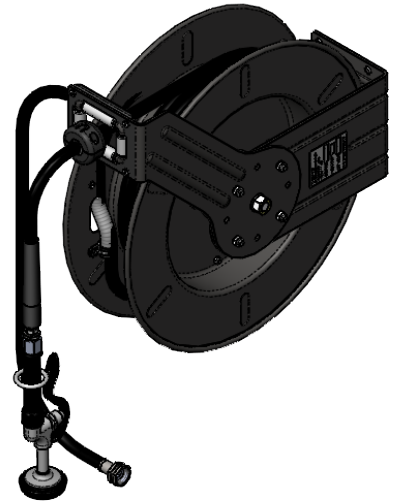
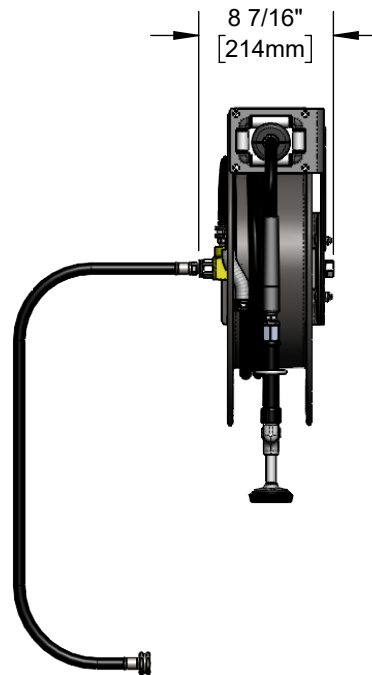
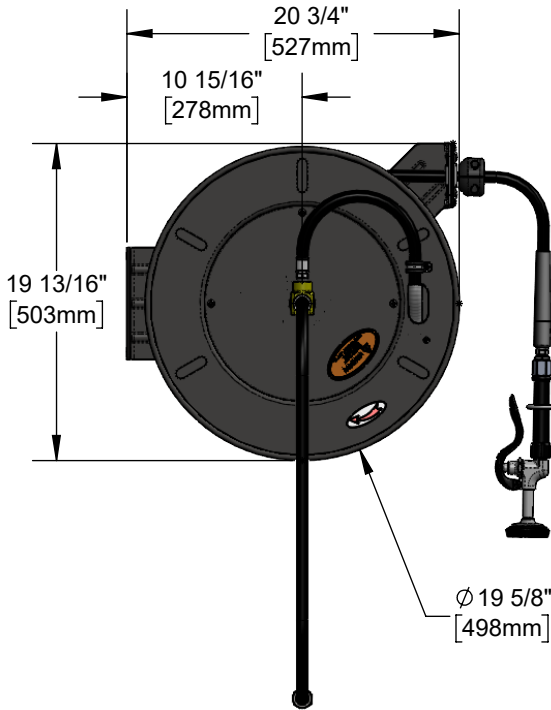

#### Features & Benefits:

- Open epoxy coated hose reel
- Black high flow spray valve
- 3/8" x 50' hose
- Ratcheting system holds the length of hose until a slight tug to retract automatically
- 3/8" NPT female inlet
- Furnished with 3' connector hose, 3/8" NPT male x garden hose swivel female
- Adjustable hose bumper
- Multi-fit bracket for wall, ceiling or under counter mounting
- Material: Epoxy coated steel open reel and wall bracket, polished chrome plated spray valve

#### Product Compliance:

- EPA 2005 Non-Compliant (PRSV)
- NSF 61 Exempt (Non-Potable)

#### Warranty: One Year (Limited)

- Hose: One Year (Limited)

#### Performance Data:

- Pressure: 20 - 125 psi [1.38-8.62 bar]
- Temperature: 40°F - 140°F [4.44°C - 60°C]
- Flow Rate: 2.53 GPM [9.6 l/min] @ 60 psi [4.14 bar]