



ADA Compliant

This Space for Architect/Engineer Approval

Job Name _____ Date _____

Model Specified _____ Quantity _____

Customer/Wholesaler _____

Contractor _____

Architect/Engineer _____

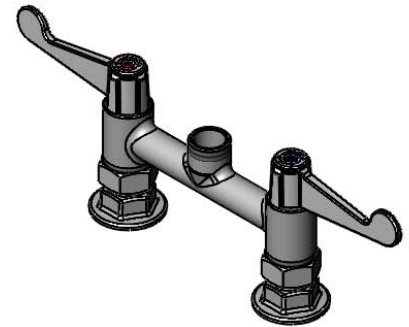
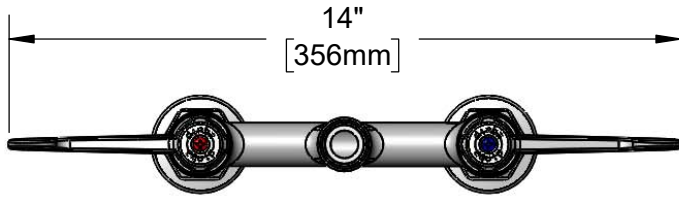

Swivel Outlet Accepts
equip Swing Nozzles.
Rigid Conversion Requires
014200-45 Lock Washer
(Sold Separately)

Quarter-Turn
Ceramic Cartridges &
equip 4" Wrist Action Handles
w/ Color Coded Screws

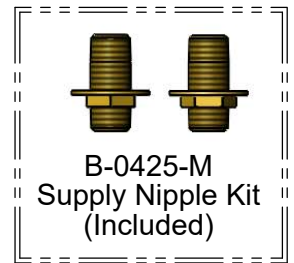
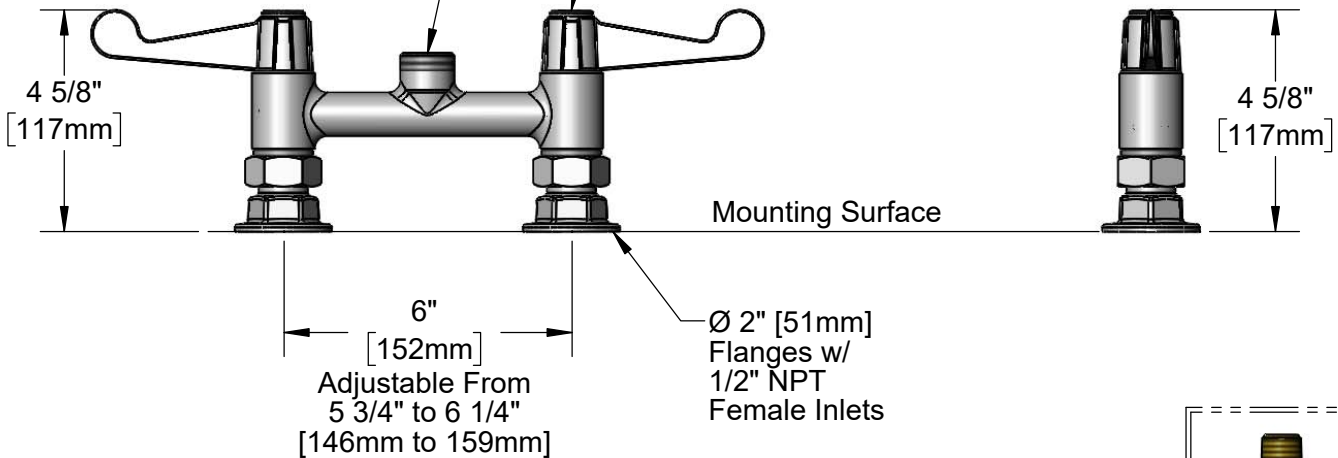

Model Number
5F-6DWS00

Product Specifications:
6" Deck Mount Mixing Faucet, Quarter-Turn Ceramic Cartridges, equip 4" Wrist Action Handles & 1/2" NPT Male Supply Inlets, Less Nozzle

Product Compliance:
ASME A112.18.1 / CSA B125.1
NSF 61 - Section 9
NSF 372 (Low Lead Content)
ANSI A117.1 (ADA)

equip Foodservice Accessories



by 

2 Saddleback Cove, P.O. Box 1088
Travelers Rest, South Carolina 29690
Phone: 800.891.4808 Fax: 800.868.0084
equip.tsbrass.com

ITEM NO.	SALES NO.	DESCRIPTION
1	5-HDL-W	equip 4" Wrist Action Handle w/ Color Coded Screws
2	013788-45	equip Ceramic Cartridge, LTC
3	001019-45	Coupling Nut Washer
4	00AA	1/2" NPT Female Eccentric Flange
5	013787-45	equip Ceramic Cartridge, RTC
6	B-0425-M	1/2" NPT Supply Nipple Kit (2)

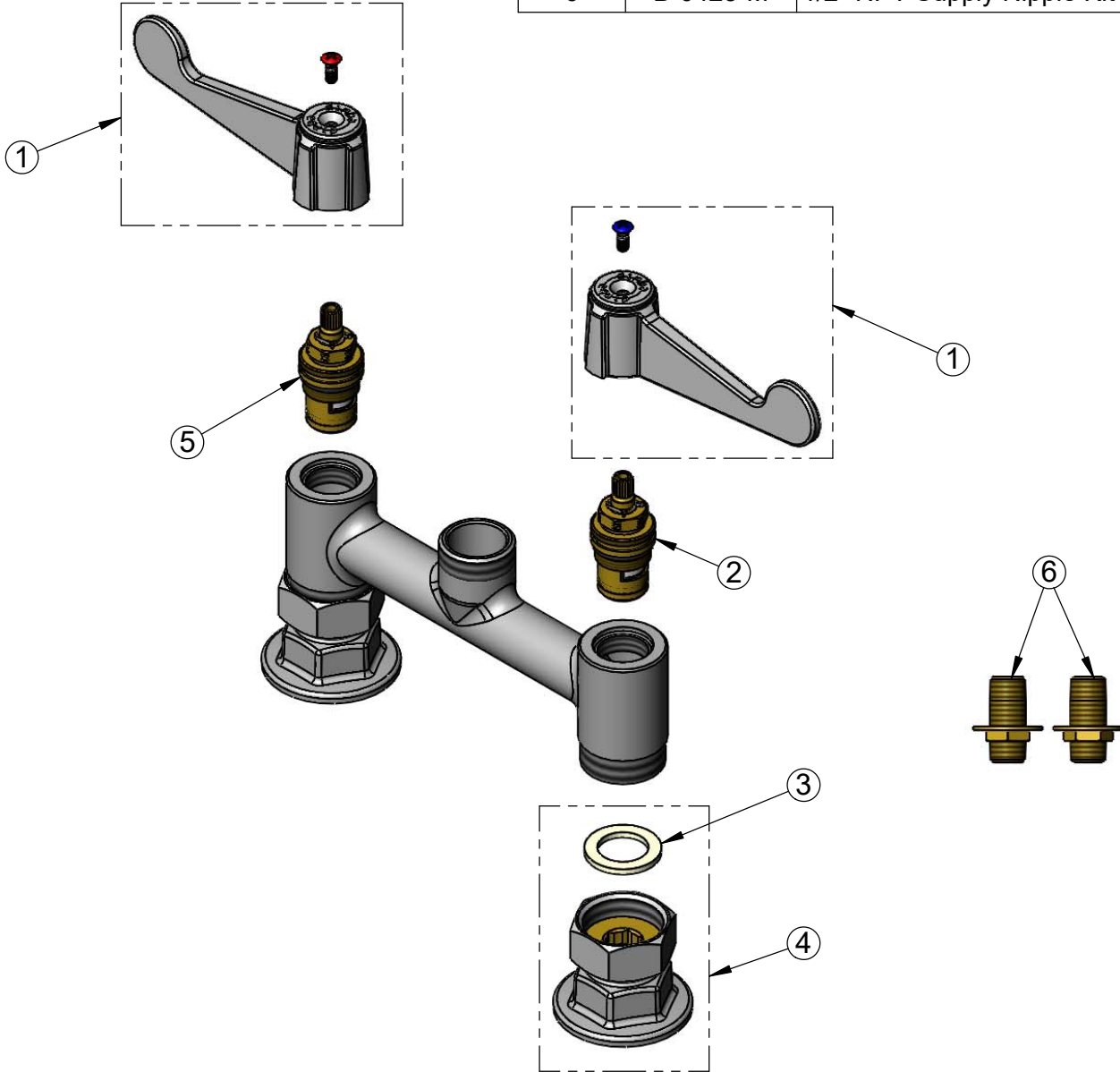

Model Number

5F-6DWS00

Product Specifications:

6" Deck Mount Mixing Faucet, Quarter-Turn Ceramic Cartridges, equip 4" Wrist Action Handles & 1/2" NPT Male Supply Inlets, Less Nozzle

Product Compliance:

ASME A112.18.1 / CSA B125.1
NSF 61 - Section 9
NSF 372 (Low Lead Content)
ANSI A117.1 (ADA)

equip
Foodservice
Accessories

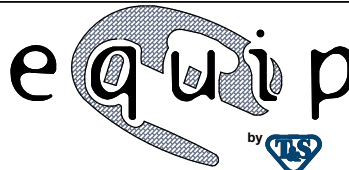

2 Saddleback Cove, P.O. Box 1088
Travelers Rest, South Carolina 29690
Phone: 800.891.4808 Fax: 800.868.0084
equip.tsbrass.com