

Architect/Engineering Specifications:

Polish chrome plated mixing valve with integral check valves and 1/2" NPSM inlets and outlet. Certified to ASME A112.18.1/CSA B125.1, NSF 61-Section 9 and NSF 372.

Job Name _____
 Model Specified _____ Quantity _____
 Variations Specified _____
 Date _____

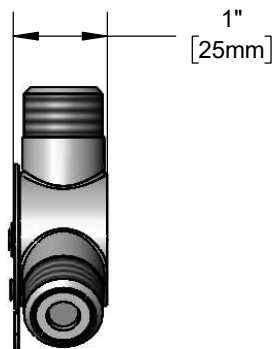
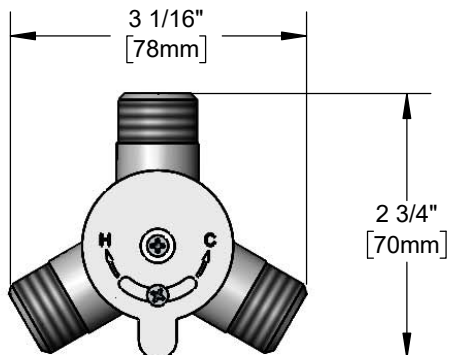
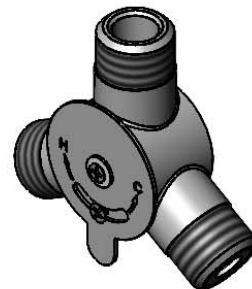

Features & Benefits:

- Chrome plated mixing valve
- Integral check valves at both inlets
- 1/2" NPSM inlets and outlet
- Material: Polished chrome plated brass

Product Compliance:

- ASME A112.18.1 / CSA B125.1
- NSF 61 - Section 9
- NSF 372 (Low Lead Content)



Warranty: One Year (Limited)



Performance Data:

- Pressure: 20 - 125 psi [1.38 - 8.62 bar]
- Temperature: 40 °F - 140 °F [4.44 °C - 60 °C]
- Flow Rate: 7.20 GPM [27.3 L/min] @ 60 psi [4.14 bar]