

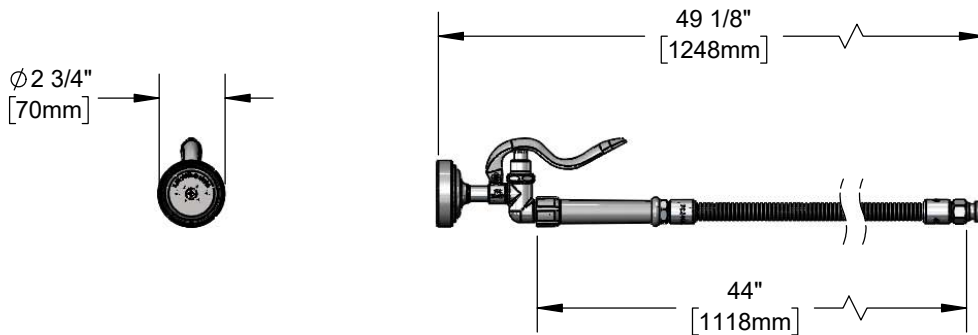

Architect/Engineering Specifications:

1.15 GPM spray valve, polished chrome plated body, 44" flexible stainless steel hose, heat resistant handle, and 1/2" NPT male inlet. Certified to ASME A112.18.1/CSA B125.1, NSF 61-Section 9, NSF 372. 2019 DOE PRSV - Class II compliant.

Job Name _____
 Model Specified _____ Quantity _____
 Variations Specified _____
 Date _____



Features & Benefits:

- Designed for heavy-duty use in industrial kitchens
- 1.15 GPM spray valve
- 44" flexible stainless steel hose w/ heat resistant gray handle and hold down ring
- 1/2" NPT male inlet
- Material: Polished chrome plated brass body and stainless steel hose

Product Compliance:

- ASME A112.18.1 / CSA B125.1
- NSF 61 - Section 9
- NSF 372 (Low Lead Content)
- 2019 DOE PRSV - Class II

Warranty: One Year (Limited)

Performance Data:

- Pressure: 20 - 125 psi
- Temperature: 40 °F - 140 °F
- Flow Rate: 1.15 GPM @ 60 psi

