



# Foot Pedal Valves

## B-0505-SL

TAG:

### Double Pedal Valve

#### Architect/Engineering Specifications:

Ledge mounted double pedal valve with chrome plated solid brass body, adjustable height aluminum pedals, metering cartridges, 1/2" NPT female inlets, 1/2" NPT female outlet and mounting screws. Certified to ASME A112.18.1/CSA B125.1, NSF 61-Section 9 and NSF 372.

Job Name \_\_\_\_\_  
 Model Specified \_\_\_\_\_ Quantity \_\_\_\_\_  
 Variations Specified \_\_\_\_\_  
 Date \_\_\_\_\_

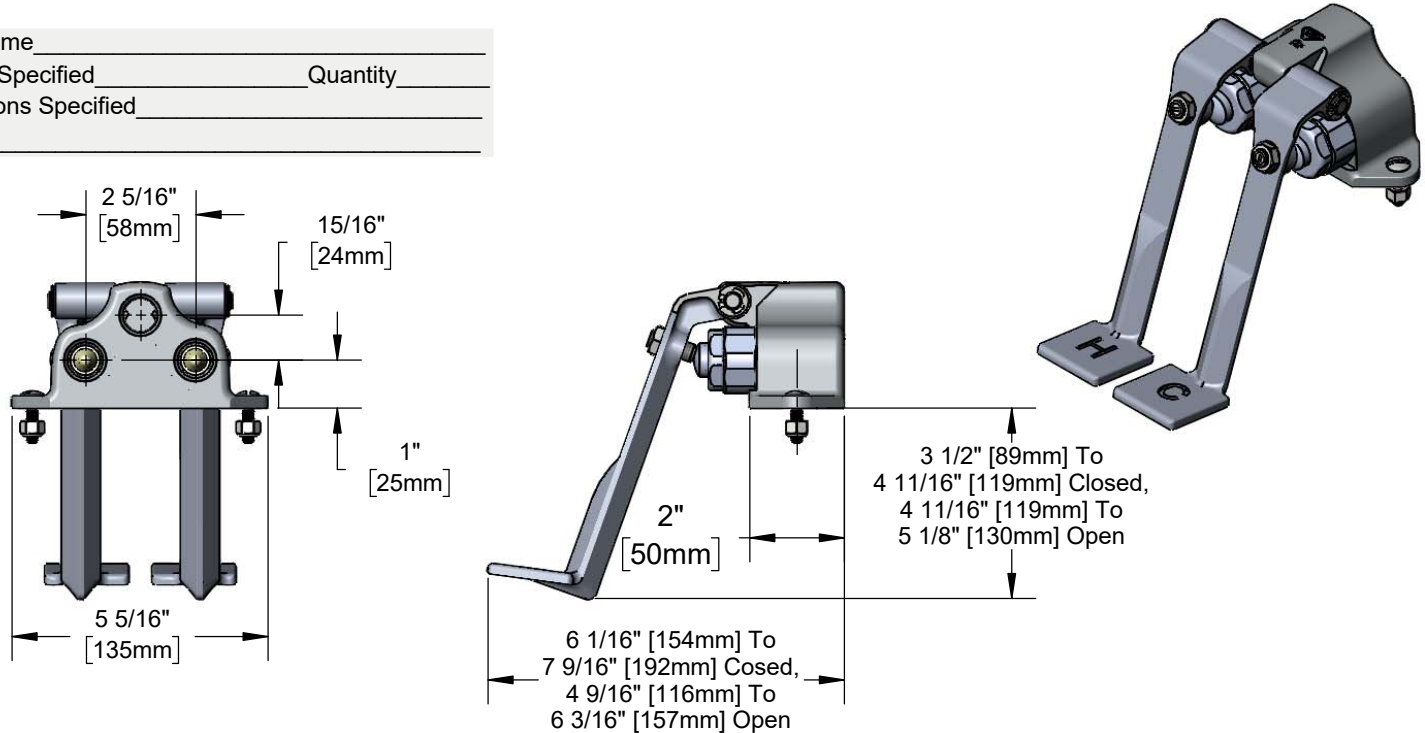

#### Features & Benefits:

- Ledge mounted double pedal valve w/ polished chrome plated brass body
- Adjustable height hot and cold pedals
- Metering cartridges
- Adjustable metering cycle 10 to 30 seconds
- 1/2" NPT female inlets and outlet
- Includes mounting screws
- Material: Polished chrome brass body, satin finish aluminum pedals

#### Optional Cartridges

- Fast Self-Closing Cartridge
- Metering Cartridge (Standard)

#### Product Compliance:

- ASME A112.18.1 / CSA B125.1
- NSF 61 - Section 9
- NSF 372 (Low Lead Content)



#### Warranty: One Year (Limited)

#### Performance Data:

- Pressure: 20 - 125 psi
- Temperature: 40 °F - 140 °F
- Flow Rate: 6.92 GPM @ 60 psi
- Water Consumption: @ 10 sec = 1.2 gal  
@ 15 sec = 1.7 gal



T&S BRASS AND BRONZE WORKS, INC.



• 2 Saddleback Cove • Travelers Rest, SC 29690  
 Ph 800-476-4103 • Fax 864-834-3518  
 • Simi Valley, CA • Ph 800-423-0150 • www.tsbrass.com

Date: 11/21/19