

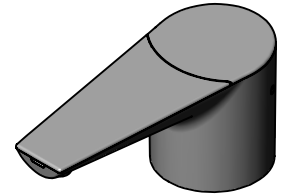

Architect/Engineering Specifications:

Electronic sensor foam soap dispenser with polished chrome spout, lockable rotating lid, top fill funnel, and AC adapter.

Job Name _____
Model Specified _____ Quantity _____
Variations Specified _____
Date _____

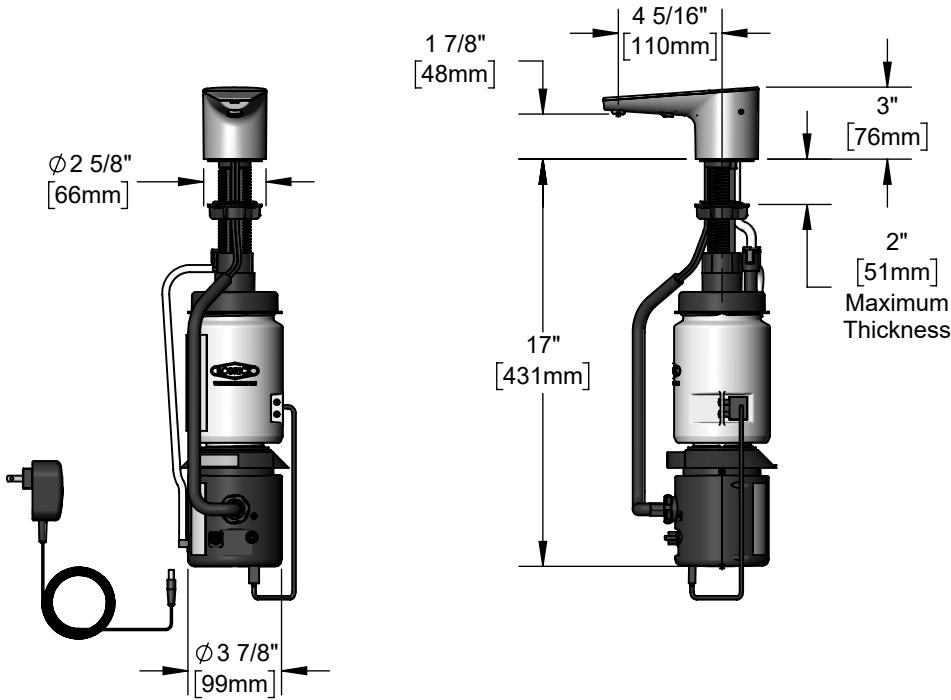

Features & Benefits:

- Electronic sensor foam soap dispenser
- Polished chrome spout
- Top fill funnel beneath rotating lid with locking mechanism
- Uses commercially available all purpose foam hand soap
- 100-240 VAC adapter
- Material: Polished chrome metal spout

Product Compliance:

- N/A

Warranty: Three Years (Limited)

Performance Data:

- Capacity: 34 oz [1 L]

