



Architect/Engineering Specifications:

Swivel sleeve. Certified to NSF 61-Section 9.

Job Name \_\_\_\_\_

Model Specified \_\_\_\_\_ Quantity \_\_\_\_\_

Variations Specified \_\_\_\_\_

Date \_\_\_\_\_

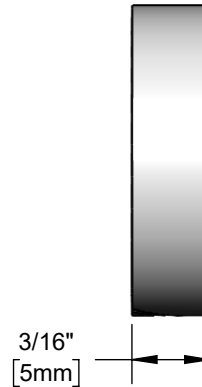
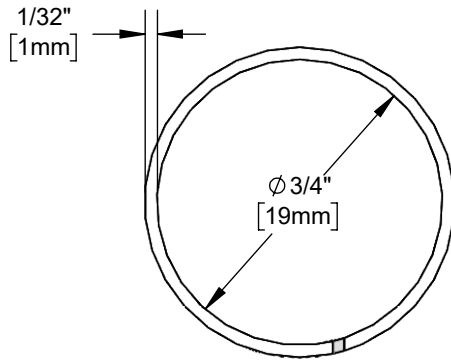

Features & Benefits:

- Swivel Sleeve
- Material: Acetal (POM)

Product Compliance:

- NSF 61 - Section 9
- WRAS Approved
- KTW-BWGL Approved

Warranty: One Year (Limited)

Performance Data:

- N/A

