

*This Space for Architect/Engineer Approval*

Job Name \_\_\_\_\_ Date \_\_\_\_\_  
 Model Specified \_\_\_\_\_ Quantity \_\_\_\_\_  
 Customer/Wholesaler \_\_\_\_\_  
 Contractor \_\_\_\_\_  
 Architect/Engineer \_\_\_\_\_

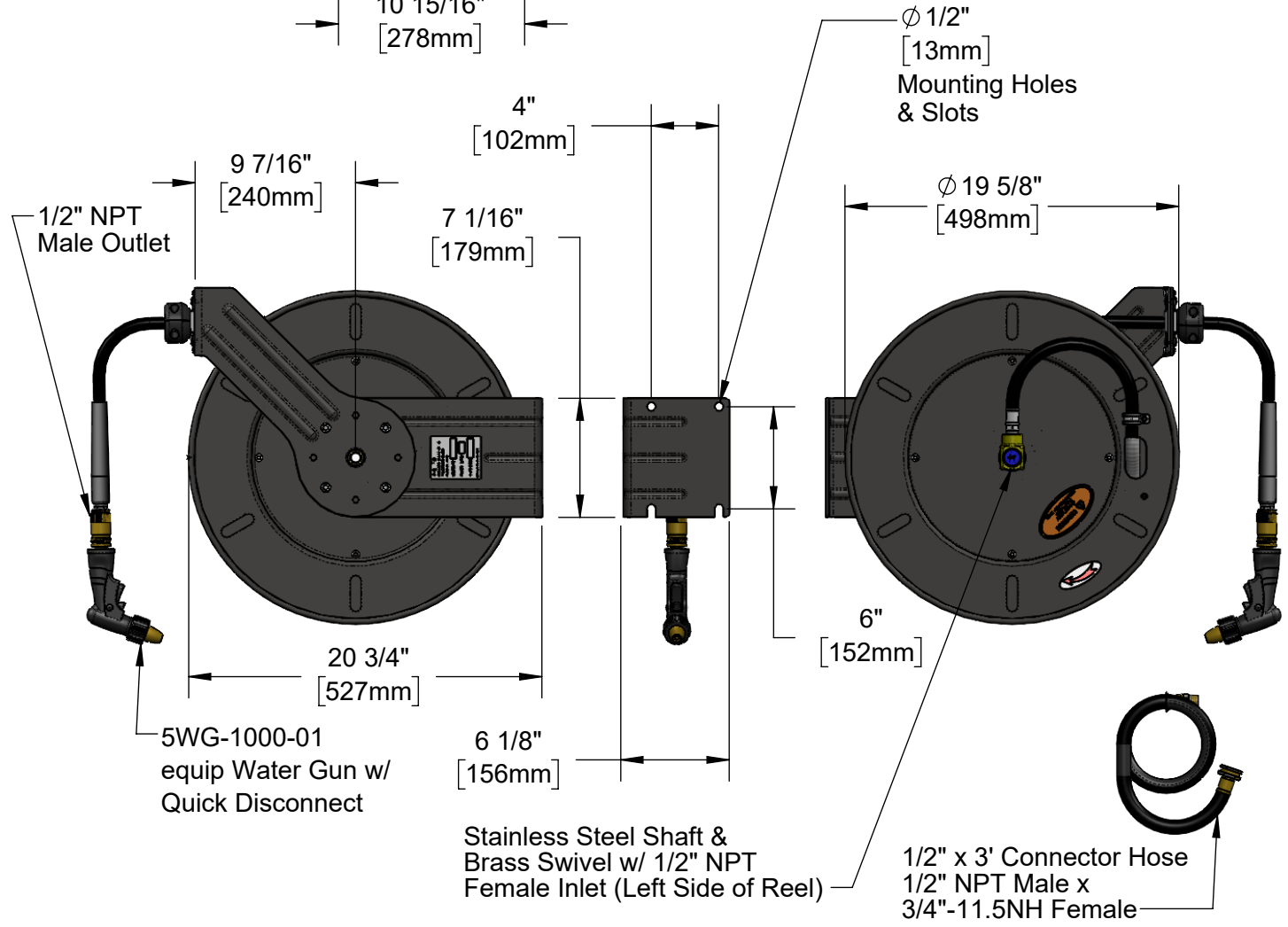
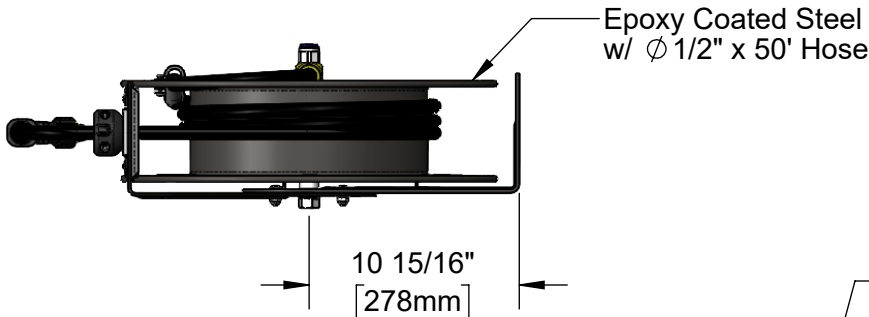

Model Number  
**5HR-342-09-GH**

Product Compliance:  
NSF 61 Exempt (Non-Potable)  
EPAAct 2005 Non-Compliant (PRSV)

Product Specifications:  
Epoxy Coated Steel, Open Hose Reel  
w/  $\varnothing$  1/2" x 50' Hose, 3' Black Connector Hose,  
Garden Hose Inlet & equip Water Gun w/  
Quick Disconnect

equip Foodservice Accessories

2 Saddleback Cove, P.O. Box 1088  
Travelers Rest, South Carolina 29690  
Phone: 800.891.4808 Fax: 800.868.0084  
equip.tsbrass.com

ITEM NO.	SALES NO.	DESCRIPTION
1	G016629-45	Complete 1/2" Swivel
2	G016684-45	Spring
3	014940-45	Ratchet Repair Kit
4	014950-45	1/2" Hose Stop Repair Kit
5	5WG-1000-01	equip Water Gun w/ Quick Disconnect
6	G016635-45	Roller Kit
7	5HR-3HSE-50	Ø 1/2" x 50' Hose
8	019473-45	Seal Kit

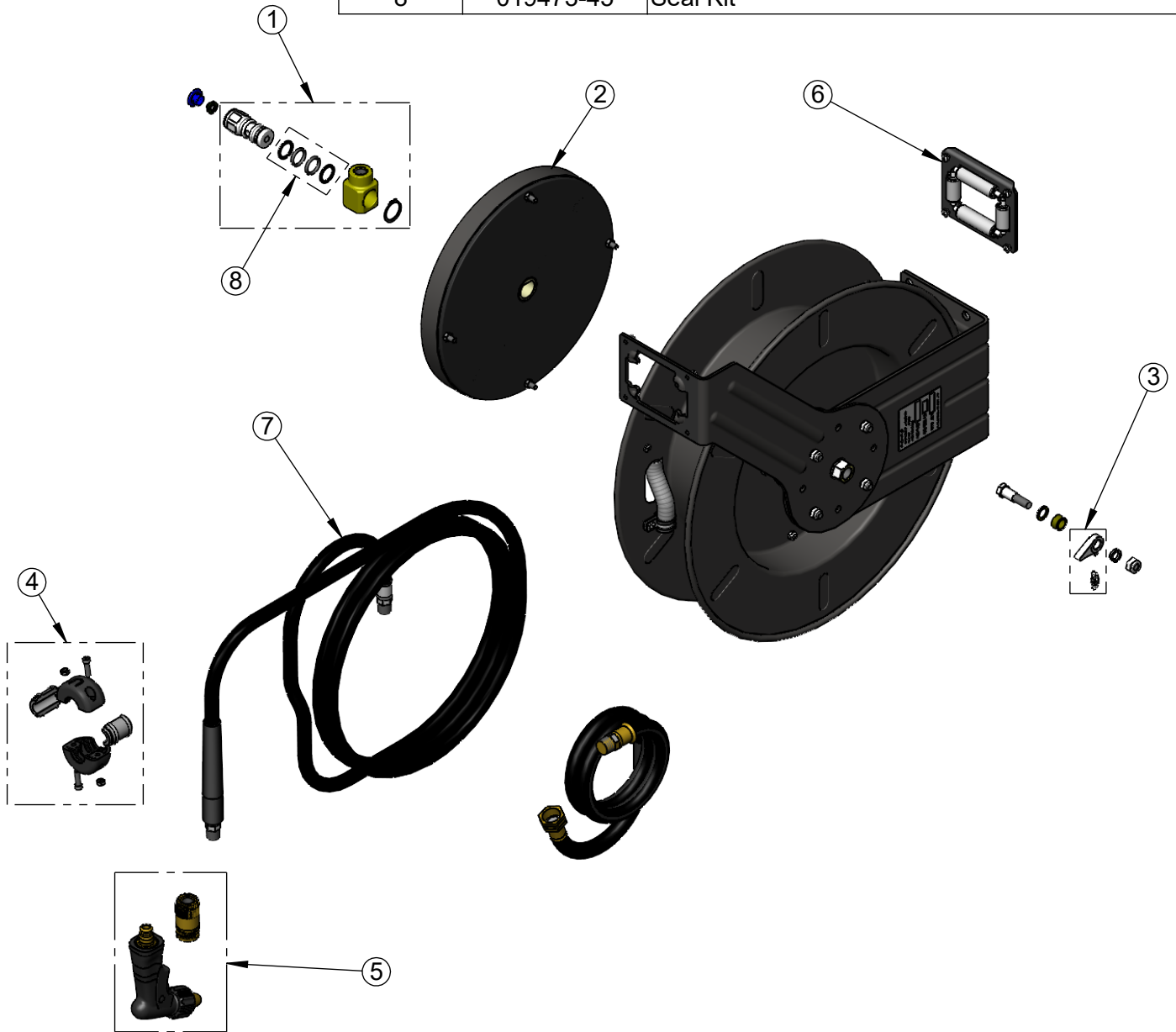

Model Number

**5HR-342-09-GH**

Product Specifications:

Epoxy Coated Steel, Open Hose Reel  
w/ Ø1/2" x 50' Hose, 3' Black Connector Hose,  
Garden Hose Inlet & equip Water Gun w/  
Quick Disconnect

Product Compliance:

NSF 61 Exempt (Non-Potable)  
EPA Act 2005 Non-Compliant (PRSV)

equip  
Foodservice  
Accessories

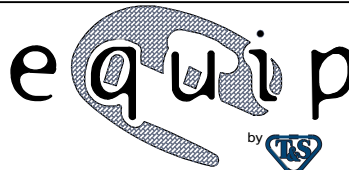

2 Saddleback Cove, P.O. Box 1088  
Travelers Rest, South Carolina 29690  
Phone: 800.891.4808 Fax: 800.868.0084  
equip.tsbrass.com

Drawn: MDF

Checked: DMH

Approved: JHB

Date: 10/18/24

Scale: NTS

Sheet: 2 of 2