

*This Space for Architect/Engineer Approval*

Job Name \_\_\_\_\_ Date \_\_\_\_\_  
 Model Specified \_\_\_\_\_ Quantity \_\_\_\_\_  
 Customer/Wholesaler \_\_\_\_\_  
 Contractor \_\_\_\_\_  
 Architect/Engineer \_\_\_\_\_

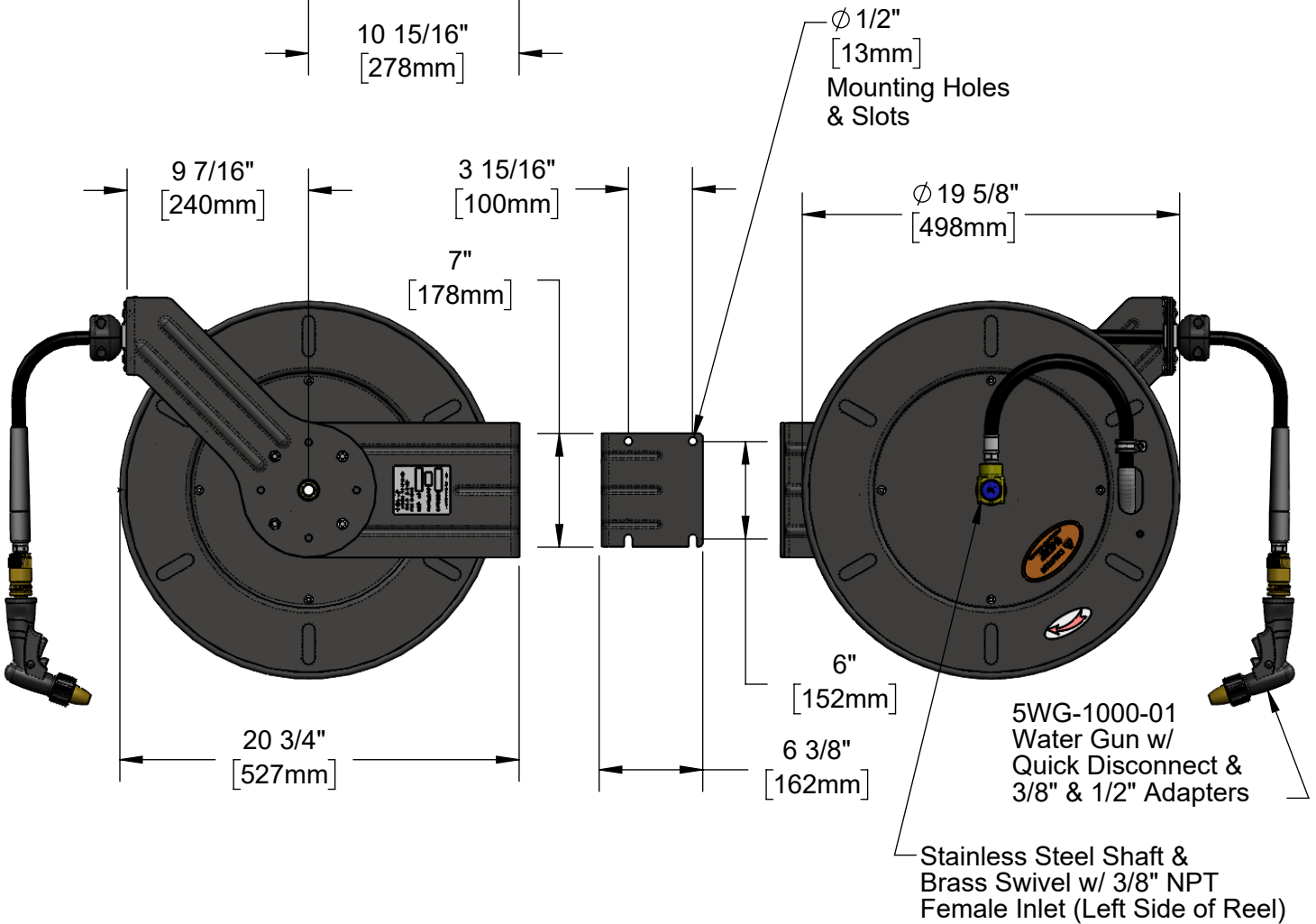
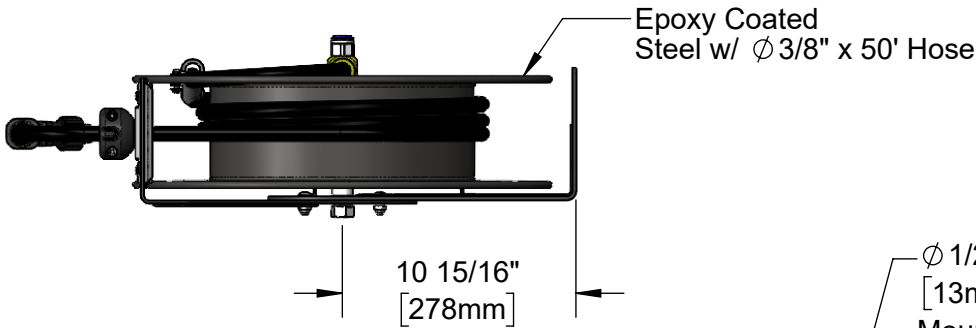

Model Number

**5HR-242-09**

Product Specifications:

Epoxy Coated Steel, Open Hose Reel  
 w/  $\varnothing$  3/8" x 50' Hose & Water Gun w/ Adapters

Product Compliance:

EPAAct 2005 Non-Compliant (PRSV)  
 NSF 61 Exempt (Non-Potable)

equip  
 Foodservice  
 Accessories

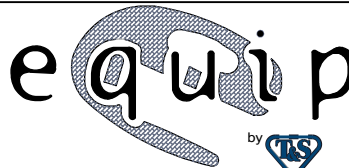

2 Saddleback Cove, P.O. Box 1088  
 Travelers Rest, South Carolina 29690  
 Phone: 800.891.4808 Fax: 800.868.0084  
 equip.tsbrass.com

ITEM NO.	SALES NO.	DESCRIPTION
1	5HR-2SA	Complete 3/8" Swivel
2	014948-45	Seal Kit
3	G016684-45	Spring
4	014940-45	Ratchet Repair Kit
5	5HR-2HSE-50	Ø 3/8" x 50' Hose
6	5WG-1000-01	equip Water Gun w/ QD, 3/8" & 1/2" Adapters
7	019246-45	Hose Stop Repair Kit
8	G016635-45	Roller Kit

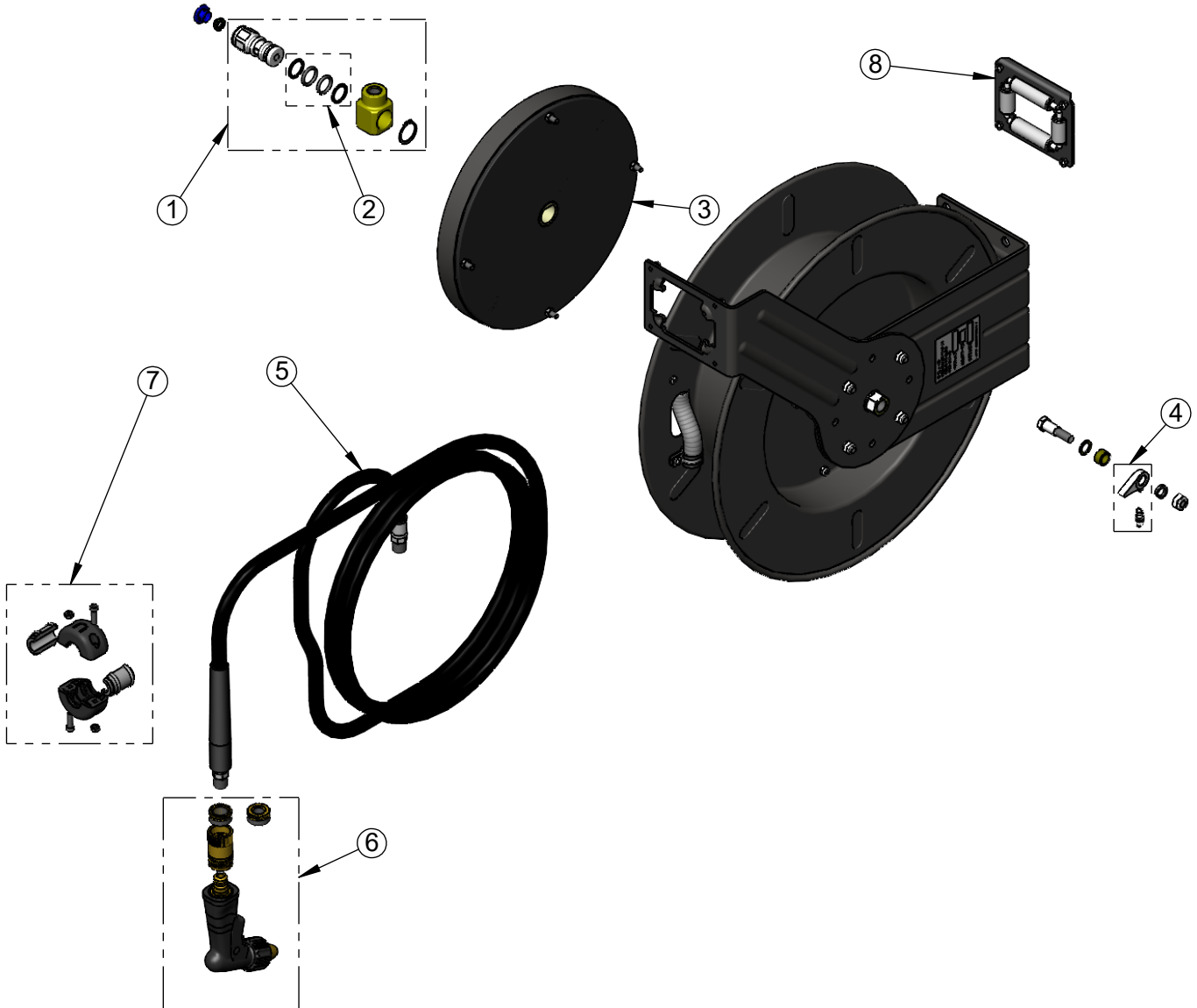

Model Number

**5HR-242-09**

Product Specifications:

Epoxy Coated Steel, Open Hose Reel  
w/ Ø3/8" x 50' Hose & Water Gun w/ Adapters

Product Compliance:

EPA Act 2005 Non-Compliant (PRSV)  
NSF 61 Exempt (Non-Potable)

equip  
Foodservice  
Accessories

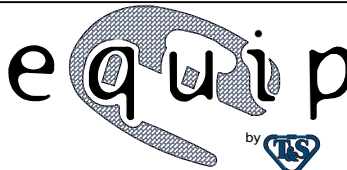

2 Saddleback Cove, P.O. Box 1088  
Travelers Rest, South Carolina 29690  
Phone: 800.891.4808 Fax: 800.868.0084  
equip.tsbrass.com

Drawn: MDF

Checked: DMH

Approved: JHB

Date: 10/18/24

Scale: NTS

Sheet: 2 of 2