

Architect/Engineering Specifications:

Open epoxy coated steel hose reel, black front trigger water gun, 1/2" x 50' hose, ratcheting system, multi-fit bracket, adjustable hose bumper, 3' connector hose and 1/2" NPT female inlet.

Job Name _____
 Model Specified _____ Quantity _____
 Variations Specified _____
 Date _____

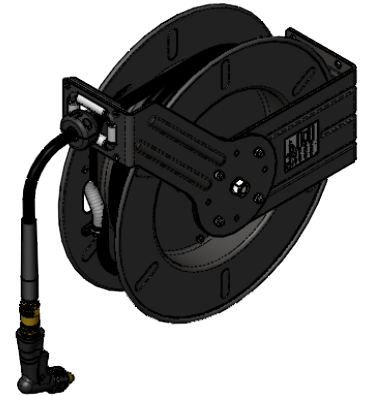
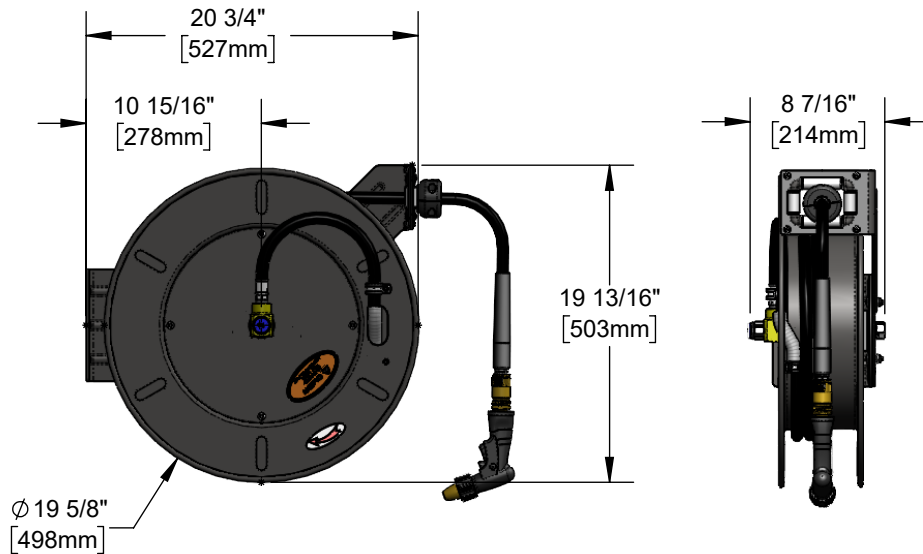

Features & Benefits:

- Open epoxy coated hose reel
- Black front trigger water gun
- 1/2" x 50' hose
- Ratcheting system holds the length of hose until a slight tug to retract automatically
- 1/2" NPT female inlet
- Adjustable hose bumper
- Multi-fit bracket for wall, ceiling or under counter mounting
- 3' connector hose included
- Material: Epoxy coated steel open reel and wall bracket, polished chrome plated spray valve

Product Compliance:

- NSF 61 Exempt (Non-Potable)
- EPA 2005 Non-Compliant (PRSV)

Warranty: One Year (Limited)

- Hose: One Year (Limited)

Performance Data:

- Pressure: 20 - 125 psi [1.38 - 8.62 bar]
- Temperature: 40°F - 140°F [4.44°C - 60°C]
- Flow Rate: 3.47 GPM [14.0 l/min] @ 60 psi [4.14 bar]