

Architect/Engineering Specifications:

Open epoxy coated steel hose reel, black front trigger spray valve, 3/8" x 50' hose, ratcheting system, multi-fit bracket, adjustable hose bumper, 3/8" NPT female inlet and 3/8" NPT male x 1/2" NPT female reducing adapter.

Job Name _____
Model Specified _____ Quantity _____
Variations Specified _____
Date _____

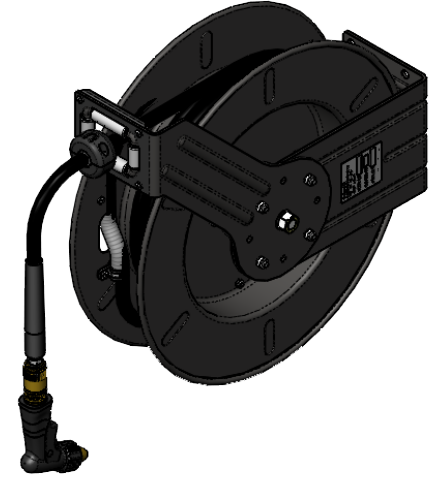
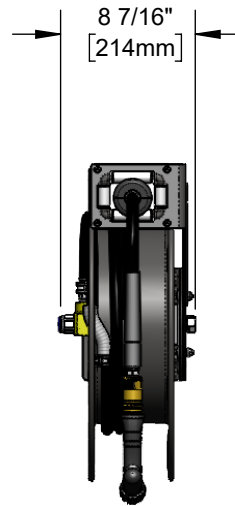
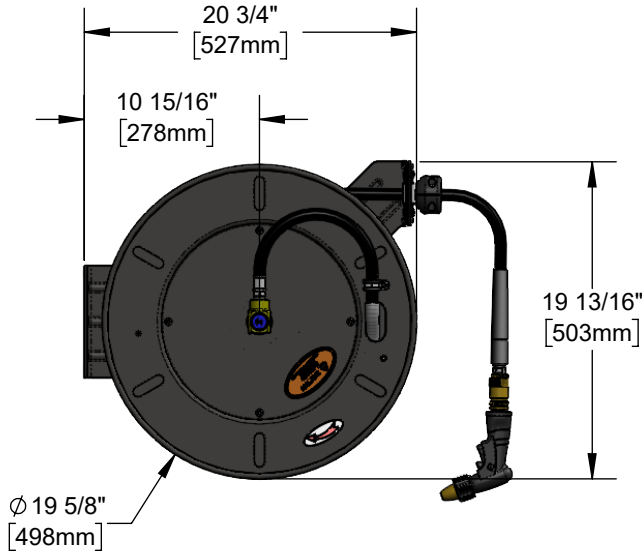

Features & Benefits:

- Open epoxy coated hose reel
- Black front trigger water gun
- 3/8" x 50' hose
- Ratcheting system holds the length of hose until a slight tug to retract automatically
- 3/8" NPT female inlet
- 3/8" NPT male x 1/2" NPT female reducing adapter included
- Adjustable hose bumper
- Multi-fit bracket for wall, ceiling or under counter mounting
- Material: Epoxy coated steel open reel and wall bracket

Product Compliance:

- EPA 2005 Non-Compliant (PRSV)
- NSF 61 Exempt (Non-Potable)

Warranty: One Year (Limited)

- Hose: One Year (Limited)

Performance Data:

- Pressure: 20 - 125 psi [1.38-8.62 bar]
- Temperature: 40°F - 140°F [4.44°C - °C]
- Flow Rate: 2.89 GPM [10.9 l/min] @ 60 psi [4.14 bar]