

*This Space for Architect/Engineer Approval*

Job Name \_\_\_\_\_ Date \_\_\_\_\_  
 Model Specified \_\_\_\_\_ Quantity \_\_\_\_\_  
 Customer/Wholesaler \_\_\_\_\_  
 Contractor \_\_\_\_\_  
 Architect/Engineer \_\_\_\_\_

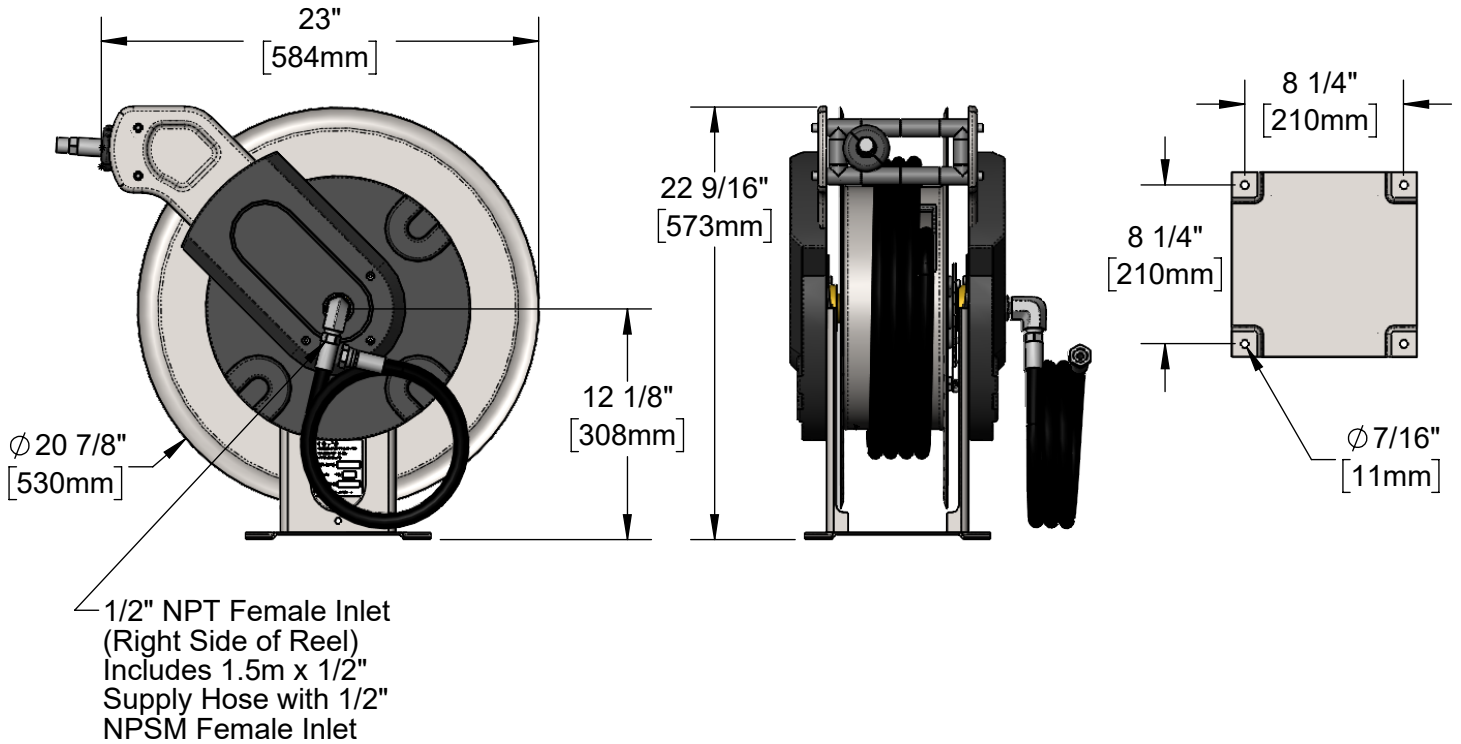
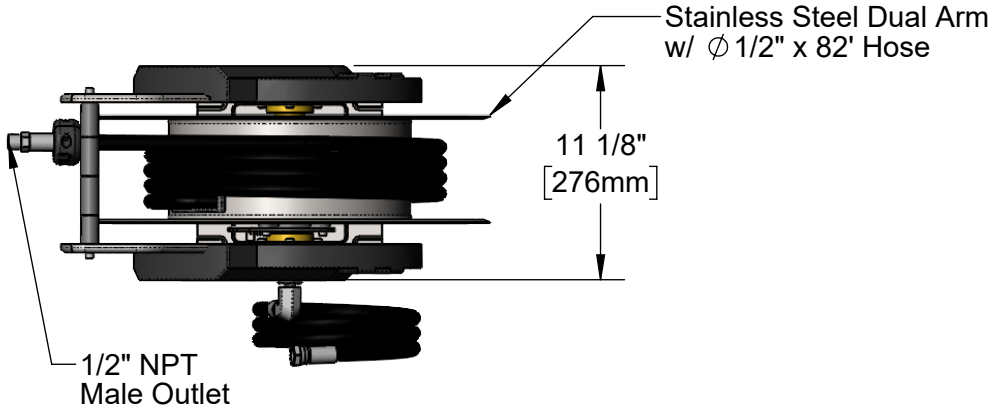
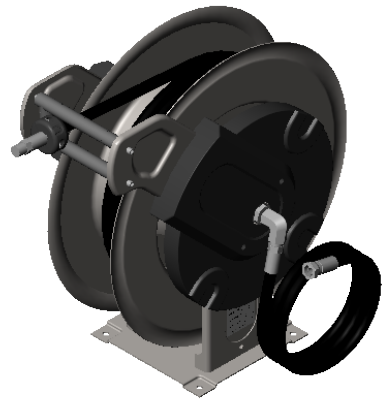

Model Number

**5HR-361**

Product Specifications:

**Stainless Steel, Open, Dual Arm Hose Reel  
w/  $\varnothing$  1/2" x 82' Hose, Less Spray Valve**

Product Compliance:

NSF 61 Exempt (Non-Potable)

equip  
Foodservice  
Accessories

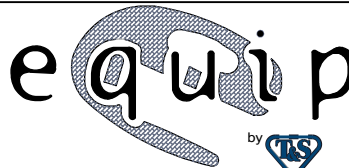

2 Saddleback Cove, P.O. Box 1088  
 Travelers Rest, South Carolina 29690  
 Phone: 800.891.4808 Fax: 800.868.0084  
 equip.tsbrass.com

ITEM NO.	SALES NO.	DESCRIPTION
1	5HR-3HSE-82	Ø 1/2" x 82' Hose
2	014950-45	Hose Stop Repair Kit
3	021133-45	1.5m x 1/2" Supply Hose

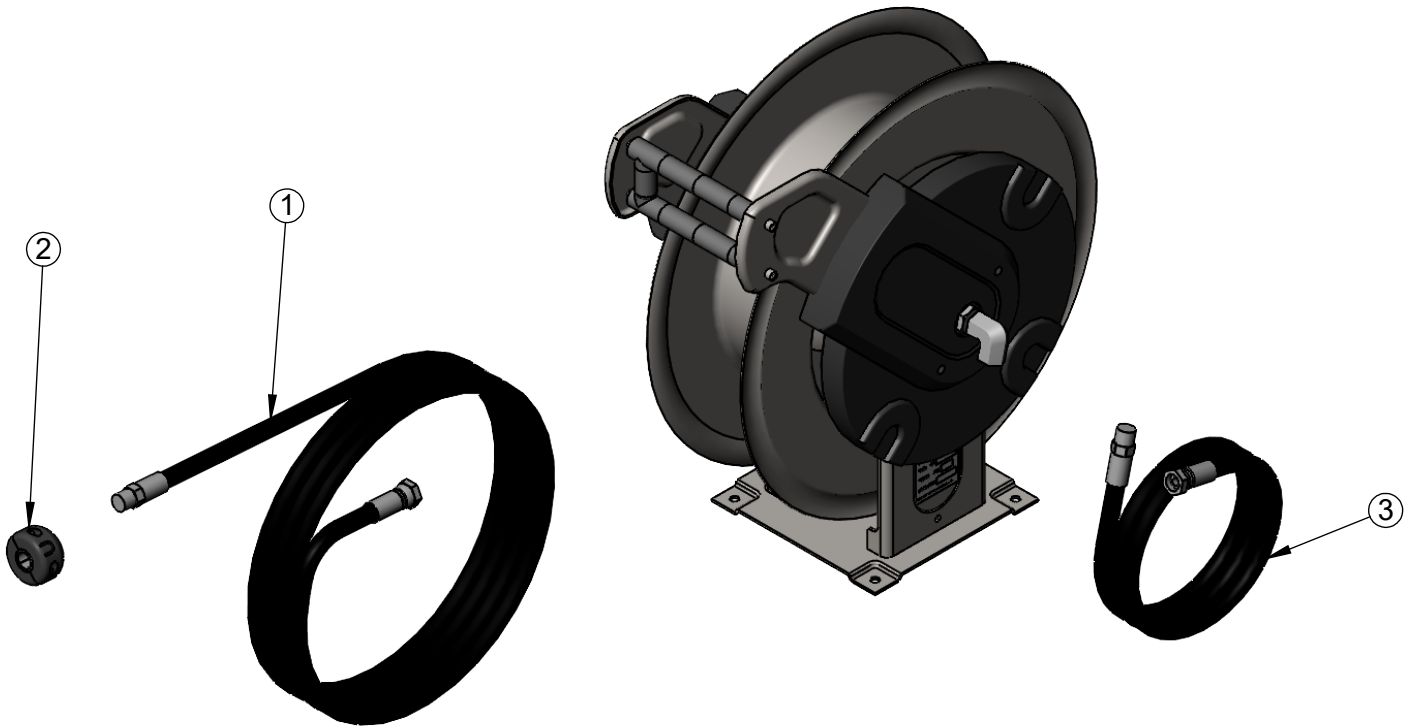

Model Number

**5HR-361**

Product Specifications:

**Stainless Steel, Open, Dual Arm Hose Reel  
w/ Ø1/2" x 82' Hose, Less Spray Valve**

Product Compliance:

NSF 61 Exempt (Non-Potable)

equip  
Foodservice  
Accessories

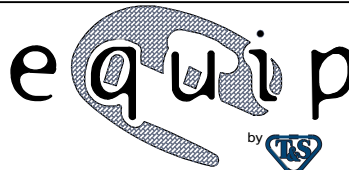

2 Saddleback Cove, P.O. Box 1088  
Travelers Rest, South Carolina 29690  
Phone: 800.891.4808 Fax: 800.868.0084  
equip.tsbrass.com