



# Epoxy Coated Retractable Hose Reels

TAG:

## 5HR-222

## Open Epoxy Coated Steel Hose Reel

### Architect/Engineering Specifications:

Open epoxy coated steel hose reel, 3/8" x 25' hose, ratcheting system, multi-fit bracket, adjustable hose bumper and 3/8" NPT female inlet and 3/8" NPT male outlet.

Job Name \_\_\_\_\_  
 Model Specified \_\_\_\_\_ Quantity \_\_\_\_\_  
 Variations Specified \_\_\_\_\_  
 Date \_\_\_\_\_

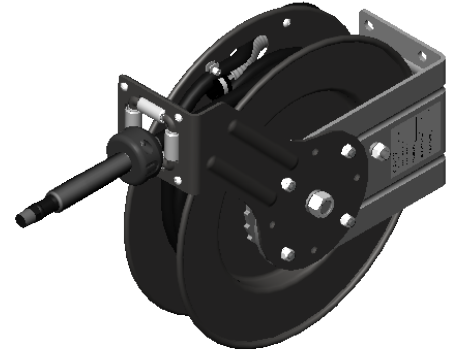
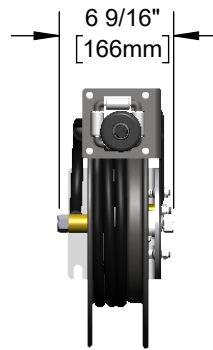
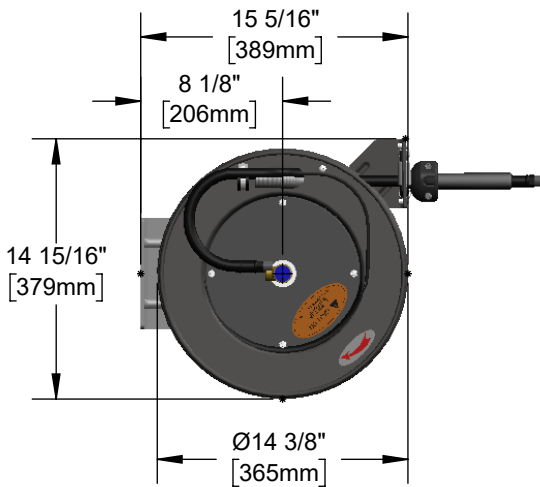

### Features & Benefits:

- Open epoxy coated hose reel
- 3/8" x 25' hose
- Ratcheting system holds the length of hose until a slight tug to retract automatically
- 3/8" NPT female inlet and 3/8" NPT male outlet
- Adjustable hose bumper
- Multi-fit bracket for wall, ceiling or under counter mounting
- Material: Epoxy coated steel open reel and wall bracket

### Product Compliance:

- NSF 61 Exempt (Non-Potable)

### Warranty: One Year (Limited)

- Hose: One Year (Limited)

### Performance Data:

- Air/Water Pressure: 300 psi [20.68] Max
- Temperature: 40°F - 140°F [4.44°C - 60°C]
- Flow Rate: 5.60 GPM [21.2 l/min] @ 60 psi [4.14 bar]

(Outlet Device &/or Final Configuration May Reduce Performance Ratings)

